



Detail Design Study for CO2 Capture and Liquefaction

PROJECT CODE: 2017.1055

PREPARED BY: Cold Logic Pty Ltd

DATE SUBMITTED: May 2017

DATE PUBLISHED: December 2017

PUBLISHED BY: AMPC

The Australian Meat Processor Corporation acknowledges the matching funds provided by the Australian Government to support the research and development detailed in this publication.

Disclaimer:

The information contained within this publication has been prepared by a third party commissioned by Australian Meat Processor Corporation Ltd (AMPC). It does not necessarily reflect the opinion or position of AMPC. Care is taken to ensure the accuracy of the information contained in this publication. However, AMPC cannot accept responsibility for the accuracy or completeness of the information or opinions contained in this publication, nor does it endorse or adopt the information contained in this report.

No part of this work may be reproduced, copied, published, communicated or adapted in any form or by any means (electronic or otherwise) without the express written permission of Australian Meat Processor Corporation Ltd. All rights are expressly reserved. Requests for further authorisation should be directed to the Executive Chairman, AMPC, Suite 1, Level 5, 110 Walker Street North Sydney NSW.



Research Organisation

Name	Cold Logic Pty Ltd
ABN	63 087 198 249
Street Address	24 Francis Street Port Adelaide SA 5015 Australia
Postal Address	PO Box 74 Port Adelaide SA 5015 Australia
Telephone	+61 (08) 8240 3333
Project Leader / Nominated Person:	
Name	Michael Riese
E-mail	Michael.Riese@coldlogic.com.au
Report Author:	Priyank Menezes
Reviewer:	Michael Riese

TABLE OF CONTENTS

1.0	EXECUTIVE SUMMARY	1
2.0	INTRODUCTION	3
2.1	Project Background	3
3.0	PROJECT OBJECTIVES	4
3.1	Limitations of the Project	4
4.0	METHODOLOGY	5
4.1.1	Amine Absorption	6
4.1.2	CO ₂ Liquefaction	8
4.2	Proposed System Design	8
5.0	PROJECT OUTCOMES	10
6.0	DISCUSSION	11
6.1	High Risk Components	11
6.2	Control Solution	13
6.2.1	Operating Schedule of the Capture Plant	14
6.2.2	Control Theory	15
6.3	Risk Minimisation Guidelines for Project Execution	18
6.4	Real Estate and Power Requirements	19
7.0	ROADMAP FOR END USERS	20
8.0	CONCLUSIONS	21
9.0	RECOMMENDATIONS	22
10.0	BIBLIOGRAPHY	24
11.0	APPENDICES	26
Appendix 1	Composition of Carbon Dioxide for Food and Beverages	26
Appendix 2	CO ₂ Capture Capacity and Natural Gas Consumption	27
Appendix 3	Flowchart for Potential End Users	28

Nomenclature

AUD	Australian Dollar
CAPEX	Capital Expenditure
CO ₂	Carbon Dioxide
FEED	Front End Engineering Design
H ₂ S	Hydrogen Sulfide
ICO ₂	Liquefied Carbon Dioxide
MEA	Monoethanolamine
n/a	Not available
N/A	Not Applicable
NH ₃	Ammonia
NO _x	Nitrogen Oxides
OPEX	Operational Expenditure
PHE	Plate Heat Exchanger
ppb	Parts per billion
ppm	Parts per million
ROI	Return on Investment
SGRS/SGR	Stack Gas Recovery System / Stack Gas Recovery
SOP	Standard Operating Procedure
SO _x	Sulphur Oxides
TBC	To be confirmed
TBD	To be determined
TPD	Tonnes per Day
TPM	Tonnes per Month
VOC	Volatile Organic Compounds

1.0 EXECUTIVE SUMMARY

Red meat processors procure liquefied Carbon Dioxide (CO_2) from gas suppliers at a significant cost for product cooling and modified atmosphere applications. This has often proven to be cost intensive and to date, no on-site CO_2 production plant has been considered. However, sufficient CO_2 capture is possible in the upstream and downstream stages of the on-site boilers. As part of Project 2016.1038, the technical and financial study into capturing CO_2 from boiler exhausts using a Stack Gas Recovery System (SGRS) was shown to be feasible.

The current project considers the technological challenges to implement such a system into an existing abattoir facility. In addition to the previously detailed post-combustion capture, the use of pre-combustion scrubbing of available biogas is also considered. In this process, CO_2 is separated from the biogas and treated to obtain food grade CO_2 , which can be further liquefied and stored. Both solutions have been considered as a means of capturing CO_2 with suitable sizing considerations. The capacity from pre-combustion capture is limited by the quantity and composition of biogas available, whereas, the post-combustion capture from boiler exhaust is capable of meeting large CO_2 demands.

The findings of this project have indicated that the capacity from pre-combustion capture is limited by the quantity and composition of biogas available. However, the post-combustion capture is capable of meeting large CO_2 demands, providing that the capture plant is optimally sized to meet current and future demands. The pay-back period for each solution is largely dependent on the ongoing procurement quantity and price of CO_2 and whether excess captured CO_2 can be retailed to gas suppliers or other users.

A generic amine absorption process and instrumentation system design has been developed for both biogas scrubbing and the SGRS. As any CO_2 capture plant integrated with an abattoir will be of a

'micro-scale' when compared to existing commercial process plants used in the oil and gas industry, a Front End Engineering Design (FEED) is required to determine the detail design of the capture plant. The concept plant design discussed in this project shows the general process systems, whilst addressing potential showstoppers that may arise during project implementation and integration with existing facilities.

High risk components as well as corrosion, foaming and amine degradation have been identified as key factors affecting the efficiency of CO₂ capture and quality of ICO₂. A detailed design with careful material selection, pre-defined control solution and regular inspections can mitigate these risks. A control approach has been developed to address the sizing considerations for a CO₂ capture plant. The project has also outlined a roadmap to aid red meat processors in determining the optimum capture solution for a given abattoir, whilst considering the existing infrastructure available for integration and the requirements of the capture plant.

The project has addressed the challenges in implementing a CO₂ capture plant at an abattoir by utilising existing resources. The on-site plant will allow red meat processors to reduce CO₂ procurement costs and provide flexibility in addressing the CO₂ requirements. Due to the small capacity of any capture plant in abattoirs, a FEED study is required to determine a detailed design for a pilot plant. This will allow for an accurate CAPEX and OPEX estimation whilst defining operating conditions, material specification and process flow analysis specific to a given case.



2.0 INTRODUCTION

Previous work completed in Project 2016.1038 shows that post-combustion CO₂ capture from abattoir steam boilers has been identified as a potential source of liquefied CO₂ (lCO₂) to replace third party sourcing. The outcomes from this project have been taken into consideration in establishing the current project, along with the possibility of utilising pre-combustion CO₂ capture. The milestone report for this project, detailed a concept design for a pilot plant including process and instrumentation design, interface points and potential showstoppers. This provided a basis for the project to determine high risk components and control solution associated with a CO₂ capture plant. A roadmap is also developed for potential end-users to assess the technical and financial feasibility of a CO₂ capture plant at an existing abattoir.

2.1 Project Background

Liquefied Carbon Dioxide (lCO₂) is used on a daily basis in the red meat industry to produce dry ice snow for product cooling applications, or in lesser concentration as modified atmosphere during the slaughtering of pigs. Traditionally, CO₂ has been procured from third party suppliers through supply agreements and spot market purchases. This is due to the fact that no consideration has been given to the in-house generation of CO₂.

As a precursor to the current project described in this report, Project 2016.1038 investigated the technical and financial feasibility of generating CO₂ on-site in a typical abattoir using stack gas recovery from the existing steam boilers. This solution was found to be technically feasible and an in-depth evaluation of the financial investment was undertaken.

The current project aims to further investigate the capture of CO₂, both upstream and downstream of the combustion process in steam boilers. The project outlines the concept design and the integration of a CO₂ capture plant with the existing infrastructure in the abattoir.

3.0 PROJECT OBJECTIVES

The objectives for the current project are to:

1. Examine the technical and financial boundaries of CO₂ capture solutions upstream (pre-combustion) and downstream (post-combustion) of the steam boilers.
2. Identify critical system interface points for combining the new CO₂ capture system with the existing biogas feed, boiler and refrigeration system.
3. Identify potential "show-stoppers" for the implementation of the project from a technical and project life-cycle point of view.
4. Identify high risk components and develop strategies for mitigation.
5. Identify high-risk items with regards to plant control, functionality and integration of the new system.
6. Develop a roadmap for potential end-users to identify system sizing and high-risk system components.

Objectives 1 to 3 are discussed in the milestone report, while the remaining objectives are addressed in this report.

3.1 Limitations of the Project

Research undertaken during the project was restricted by a number of factors relating to technical and financial issues. CAPEX limitations for all major equipment were based upon private correspondence with an existing abattoir, having a current throughput of 4,200 heads of cattle and 55,000 lamb/mutton per week. The anaerobic digester installed in the abattoir produces approximately 8,000 cubic meters of biogas per day corresponding to the abattoir's slaughter numbers and kill days. The abattoir uses approximately 20 tonnes of ICO₂ per month for product

cooling applications. The CAPEX is subject to change depending on the slaughter rate and monthly demand for CO₂. Furthermore, the CAPEX variables including equipment installation and requirements for additional equipment will depend on the abattoir's layout and must be investigated on a case-by-case basis.

4.0 METHODOLOGY

A technical feasibility study was undertaken during the early stages of Project 2016.1038 to assess the possibility of capturing CO₂ for further processing to meet food grade standards. Appendix 1 outlines the requirements for food grade CO₂. Subject to the combustion stage of the steam boilers, CO₂ capture technologies can be separated into the following two main categories:

- **Post-Combustion Capture** - This process separates CO₂ from exhaust gas after the combustion of carbon-containing fuels. An amine-based solution is used to absorb CO₂ at low temperatures, which can then be released at high temperatures; thus allowing the separation of CO₂ from the other stack gases (MacDowell, et al., 2010). This technology is well established in a commercial environment and is suitable for both new and retrofitted projects (ASCO, 2015; TPI, 2015). The proposed system design in Project 2016.1038 for post-combustion capture plans to capture CO₂ by treating the stack gas from steam boilers. Integration of the existing refrigeration system with the CO₂ capture plant for liquefaction was also addressed. The technical and financial study showed that the Stack Gas Recovery System (SGRS) post-combustion system is a feasible solution for capturing CO₂ at food grade quality.
- **Pre-Combustion Capture** - This process splits hydrocarbons and CO₂ prior to combustion and hence may be suitable in processing plants where CO₂ rich biogas is co-fired into the steam boilers. CO₂ capture can be facilitated by a similar technology to gas the sweetening process used in the natural gas industry, involving the absorption of CO₂ through amine solvents

referred to as ‘Amine Absorption’ (De Rijke, 2012). As biogas is significantly rich in CO₂ and methane (Table 1), separation through amine absorption (Peterson & Wellinger, 2009) would result in a CO₂ rich stream and a bio-methane stream (Yousef, et al., 2016). The bio-methane stream with a higher calorific value (36.3 MJ/kg, Yousef, et al., 2016) than biogas can supplement natural gas in the boilers.

The pre-combustion system is investigated in this project to determine the potential for CO₂ capture upstream of the steam boilers. Although post-combustion capture has also been shown to provide a solution, capturing CO₂ from biogas requires less volume of raw gas per kilogram of CO₂ captured. The pre-combustion separation makes the best use of the abattoir’s existing systems whilst increasing the potential value of biogas.

Table 1: Biogas and natural gas composition

Composition	Unit	Biogas (BioEnergy, FM, n.d.)	Corresponding Abattoir’s Biogas (Fortuna, 2016)	Natural Gas (Demirbas, 2010)
Methane	%vol	50-75	73.5	95
Other Hydrocarbons	%vol	n/a	n/a	3.2
Carbon Dioxide (CO ₂)	%vol	25-50	25.9	0.6
Oxygen	%vol	0.1-2	0.58	n/a
Nitrogen	%vol	0-10	0	1.2
Hydrogen Sulphide (H ₂ S)	ppm	10-4000	852	n/a
VOCs	ppm	n/a	153	n/a
Calorific Value	MJ/kg	16-20	n/a	39.1 (Roarty, 1998)

4.1.1 Amine Absorption

Amine absorption has been previously identified as the best solution for CO₂ capture in Australia. This technology can be used for both biogas scrubbing and flue gas treatment (pre- and post-combustion). This process is commonly used for gas sweetening in the oil and gas industry and is therefore more readily available. It is also technically feasible in terms of maintenance capabilities

and custom design. It utilises an amine solution (usually Monoethanolamine (MEA)) in counter flow with raw biogas to absorb CO_2 and H_2S , in an absorber column operating close to ambient conditions (De Rijke, 2012). The rich amine solution is then boiled in a reboiler, allowing the CO_2 and H_2S to be released as gaseous vapour in the stripper column (Figure 1). The lean amine solution is then recirculated to the absorber column whilst the CO_2 gas stream is further treated to meet food grade specifications.

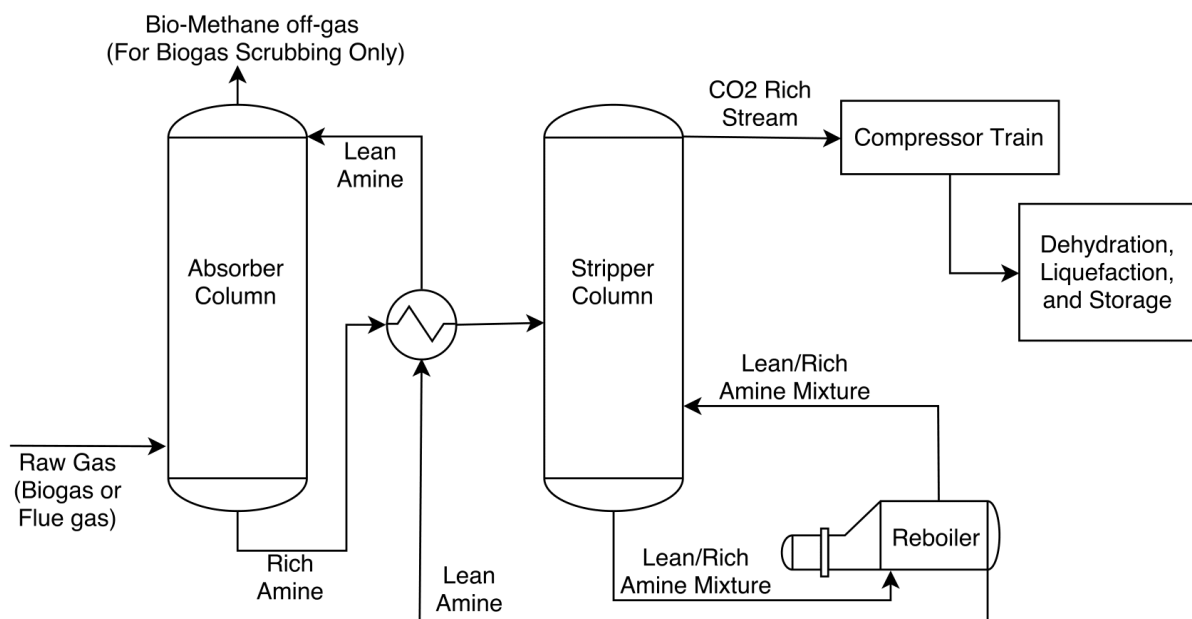

Figure 1: Amine absorption process schematic

The amine absorption process is versatile for varying compositions of raw gas and hence can also be used to capture CO_2 from the boiler exhaust gas. This solution was previously explored in Project 2016.1038, referred to as SGRS. Compared to other processes, amine absorption has relatively simple operation with no moving parts during absorption and stripping. With a counter flow absorption process and heat induced distillation, the system allows for varying capacity during operation (60-100%) (Urban, et al., 2009). This is achieved by controlling the flow of amine, allowing for more flexible operation during peak and off-peak hours. Degradation of amine solution can also occur due to impurities in raw gas, which can be minimised by pre-treatment as well as employing an amine purification module (Eco-Tec, 2016).

The biogas scrubber is limited in CO₂ capacity which may or may not meet the demands of a given abattoir. In the case where demands cannot be met, the SGRS would provide a better solution to meet current and future demands of CO₂. Although commonly used in Australia for gas sweetening, CO₂ capture on this small scale is scarcely used. Hence, a Front End Engineering Design (FEED) is required to size the plant accurately and better estimate the CAPEX and OPEX.

4.1.2 CO₂ Liquefaction

The CO₂ rich gas is compressed to 2,000 kPaG through a two stage compression system with intercooling. The compressed CO₂ is then dried to remove any moisture, followed by filtration with activated carbon washed in a caustic solution to remove the H₂S content (Filchem Australia, 2015). Assuming the CO₂ is condensed at -22 °C and 1,800 kPaG (GLP Group, 2016), the enthalpy of the superheated gas phase CO₂ is 437 kJ/kg and that of the saturated liquid is 149.2 kJ/kg (TEGA, n.d.). Hence, the heat rejection of CO₂ at this condition is 287.8 kJ/kg. Hence, for a capture plant with a production rate of 285 kg/hr, as estimated in the previous project, the cooling requirement for condensing CO₂ as food grade product is 23 kW.

4.2 Proposed System Design

Amine absorption technology has better flexibility and capture efficiency to cope with the availability of the raw gas containing CO₂. Therefore, the proposed system design caters for both stages, allowing the red meat processors to determine which solution is more suitable for their specific requirements.



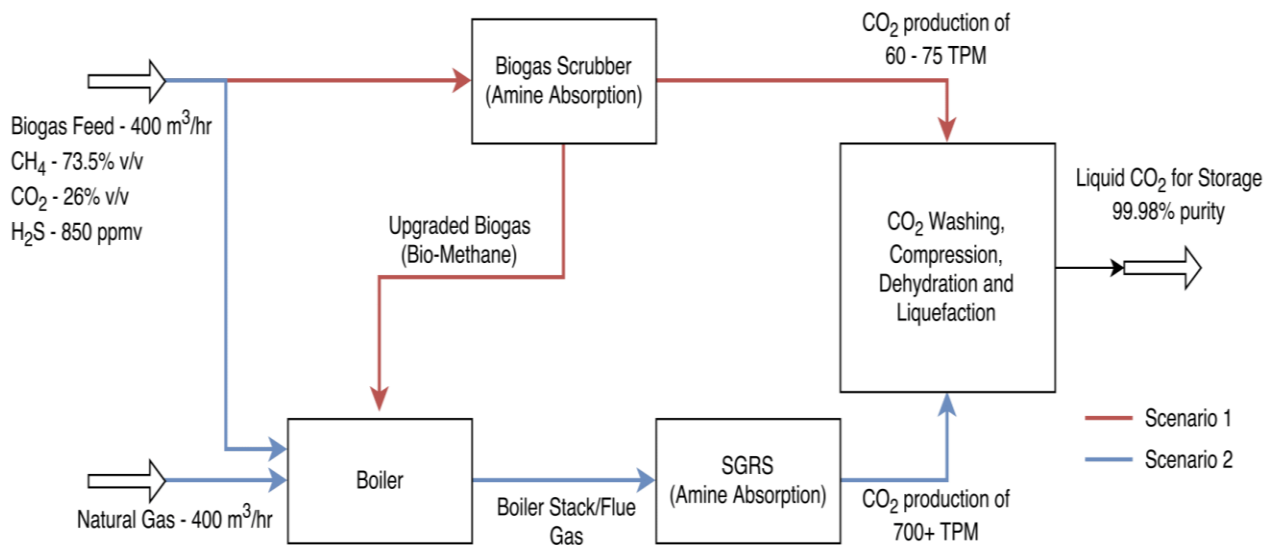

Figure 2: Flowchart for amine absorption process in pre- and post-combustion stages

The process for amine absorption is shown in Figure 2 with scenarios involving both pre- and post-combustion CO₂ capture. The two possible scenarios for an abattoir producing around 8,000 cubic meters of biogas are as follows:

- Scenario 1, Biogas Scrubber (Pre-Combustion)** – This scenario allows for biogas to be treated, capturing CO₂ and allowing the residual gas (bio-methane) to be used in the boiler to supplement natural gas. The maximum CO₂ capacity for the abattoir is about 60-75 TPM, capable of meeting current and future demands.
- Scenario 2, Stack Gas Recovery System (SRGS) (Post-Combustion)** – CO₂ is captured in stack gas from the boilers whilst using natural gas and biogas as fuel. The CO₂ capacity for capture is in excess of 700 TPM (for an 8.7MW boiler), which is significantly in excess of CO₂ demands for the abattoir. However, the system can be scaled to meet current and possible future demands for the abattoir’s operational needs. Furthermore, the excess CO₂ can also be retailed to other parties, but this may not be practical depending on the local market.

Red meat processors will need to establish whether pre- or post-combustion is best suited to meet the requirements of their abattoir. Current and future demands as well as the CO₂ capture capacity needs to be considered during the selection process.

5.0 PROJECT OUTCOMES

This project has investigated the technical design challenges for a CO₂ capture plant to be integrated into an existing abattoir. The project has shown the red meat processing industry that an on-site CO₂ capture plant is feasible to offset the CO₂ procurement cost from third parties. By utilising resources available at the existing abattoir, liquefied CO₂ can be captured to meet food grade standards.

Technical outcomes in terms of plant operation and sizing considerations between the biogas scrubber and SGRS are discussed in the milestone report. The biogas scrubber, unlike the SGRS, is very limited in CO₂ capture capacity and hence provides limited flexibility for abattoirs with large CO₂ demands. For either scenario, a sizing methodology is required with consideration of abattoir operations and CO₂ utilisation patterns to provide an optimised design solution.

Potential showstoppers and interface points are discussed in the milestone report, whilst, high risk components and operating schedule have been addressed in this report. Integration with existing biogas, boiler, refrigeration and CO₂ infrastructure will enable the abattoir to reduce capital and operational expenditure. High risk components such as corrosion, foaming and amine degradation can be mitigated with careful material selection, regular inspections and maintenance procedures.

From the outcomes of this project, it is evident that any CO₂ capture plant integrated with an abattoir is of a 'micro-scale' when compared to existing process plants used in the oil and gas industry. Therefore, only a concept design was established due to the lack of sizing and operational data on 'micro' process plants. Consequently, a FEED study is required to further understand the implications of a 'micro-size' plant on equipment sizing, control and operational boundaries.

6.0 DISCUSSION

The following section provides an analysis of the results found throughout the project. The high risk components of the capture plant, operating schedule, risk minimisation, real estate and power requirements are outlined in this section.

6.1 High Risk Components

The possible high risk components that will need to be reviewed during the detailed design of a CO₂ capture plant for a specific abattoir are discussed below. The risks are significant factors that affect the efficiency of the amine plant and the quality of the CO₂ captured.

- **Corrosion** – Corrosion and material selection is a key factor in the practical design of an amine plant to ensure optimum operational lifetime with minimal CAPEX. Corrosion occurs mainly due to the corrosive amine solution as well as acid gases such as H₂S, SO_x and NO_x. Elevated temperatures and components with high amine flowrates are also key factors affecting the corrosion rate. Material selection is used as a method to reduce the effects of corrosion specific to each case depending on the operating schedule and concentration of amine and acid gases.

An appropriate maintenance schedule with regular visual inspections of absorber and stripper column interiors and other components can ensure operational reliability of the plant. Furthermore, a monitoring system using thickness sensors can also be employed to detect corrosion at critical points. Some components such as the reboiler, stripper column and lean/rich heat exchanger are likely to experience more corrosion due to the temperature gradient and quantity of flow (Mitra, 2015).

Generally, carbon steel is often used as the material for the amine plant to reduce corrosion with 316L-grade stainless steel tubes for pipework. The absorber column may also be lined with concrete and acid resisting tiling to extend the life of the system (IEAGHG, 2010). The compressor train also uses 316L-grade stainless steel pipework with carbon steel separator

drums. An appropriately designed plant with the correct material selection and plant control to maintain concentration levels to meet design specifications will extend the life of the amine plant (Mitra, 2015).

- **Foaming** – Foaming of the amine solution is another key issue affecting the operational efficiency of the plant. Solution foaming can occur in the absorber and stripper columns and is directly responsible for the quality of the end product and throughput efficiency of the system. Foaming occurs when the vapour-liquid mixture does not meet design standards or if the amine solution is contaminated and has restricted flow (Mitra, 2015). Symptoms might involve erratic off gas rates, low or erratic column solution levels, increasing column pressure differential and off-specification CO₂ gas (Amine Best Practices, 2007). Minor foaming only impacts the efficiency of the amine plant and can be temporarily reduced by introducing antifoam agents in the flow. However, major and regular foaming incidents may suggest a design or operation fault that will require immediate assessment and resolution (De Rijke, 2012).

Clean amine solution free of contaminants will not result in foaming. Foaming occurs due to amine degradation and suspended particulates in the columns when in contact with the raw gas (Mitra, 2015). A closely monitored plant operation and appropriate filtration to maintain the quality of the amine solution will reduce foaming in the columns. Additional carbon filters and separators can further reduce contaminant levels along with a pre-wash for raw gas before the absorber column.

- **Amine Degradation** – Amine degradation can occur due to contaminants and compounds present in the raw gas such as CO₂, O₂, SO_x and NO_x, as well as thermal degradation. Poor quality amine can result in foaming when in contact with raw gas, reducing the efficiency of the plant. Hence, it is vital to maintain amine quality to ensure the throughput and quality of CO₂ meets food grade standards.

A filtration system including particulate filtration and a carbon filter is crucial to a well-designed amine plant. The particulate filter can be used to treat raw gas as well as the amine solution to remove accumulated contaminants. Similarly, the carbon filter removes other surface active contaminants and hydrocarbons in the amine solution (De Rijke, 2012). If the raw gas composition has high quantities of VOCs and SO_x, then a catalytic oxidiser or an additional amine purification module might be required to reduce amine degradation.

The amine degradation rate can also be reduced by controlling the amine flowrate and reboiler temperatures. By keeping the system within the design constraints, in terms of ratio of raw gas and amine solution, amine degradation can be minimised. The design process will also have to consider the composition of raw gas during the selection of an amine solution that is best suited to resist degradation.

CO₂ Pipelines – The CO₂ pipelines are generally stainless steel provided the quality of the CO₂ being transferred meets specifications. According to the report produced by IEAGHG (2010), stainless steel and carbon steel can be used provided the moisture content and H₂S is less than 50 ppm and 150 ppb respectively. However, failure to meet food grade standards or if moisture is leaked into the system, then pipe freezing could occur causing the pipeline to rupture.

The thickness, strength and toughness of the pipe will need to be designed specific to the application, depending on the CO₂ delivery pressure, temperature and flow rate.

6.2 Control Solution

This section addresses the operating pattern with respect to the sizing and control theory associated with the capture plant.

6.2.1 Operating Schedule of the Capture Plant

The operation of the system is largely dependent on the throughput capacity of the plant and the abattoir's demand for CO₂ and boiler operation. Data collected from the abattoir shows the weekly cycle of a typical abattoir from kill days to the final product in terms of natural gas consumption and CO₂ capture capacity (Appendix 2). As steam and CO₂ consumption predominantly occurs during the weekdays after boning, it is recommended for the capture plant to be operational during weekdays and turned off during weekends. This will ensure that the plant has enough supply of raw gas as well as steam for the reboiler to keep the capture plant operating under design conditions. However, if the boilers are already operating at peak capacity during weekdays, then a possible alternative can be to capture CO₂ during weekends at a reduced capacity. This would increase the ROI due to the additional cost of 'creating' raw gas from the boilers only for the sake of CO₂ capture.

The abattoir's CO₂ requirements and consumption rate along with future demands need to be considered to ensure appropriate sizing of a capture plant. Generally, amine plants operate as a continuous system with shutdown only occurring for maintenance. The amine absorption technology can allow for turndown capacity of up to 60% of design specifications. Shutdown on a daily basis is not technically feasible due to increased amounts of corrosion that would significantly reduce the lifespan of the key components. However, weekly shutdowns during weekends can be made possible with careful material selection and quality control of the amine solution to reduce corrosion.

Figure 3 shows two different operating cases for sizing purposes. The CO₂ capacity is based on the boiler performance of the abattoir fuelled by natural gas. The red case is designed to meet the 30TPM demand at 100% design capacity for 20 operating days in a month. This allows the plant to capture between 18 to 30TPM when operating between 60% - 100% respectively. However, the other case is designed to capture 30TPM at 70% design capacity. This allows the plant to capture

between 25 to 42TPM whilst operating between 60% - 100% respectively. As the abattoir already utilises 20TPM, with plans to expand to 30TPM, the blue case will provide the abattoir operators with the best flexibility in production rate whilst accounting for future demands. Therefore, a detailed study is required on a case-by-case basis of the abattoir’s CO₂ consumption patterns to appropriately size the capture plant whilst considering the CAPEX.

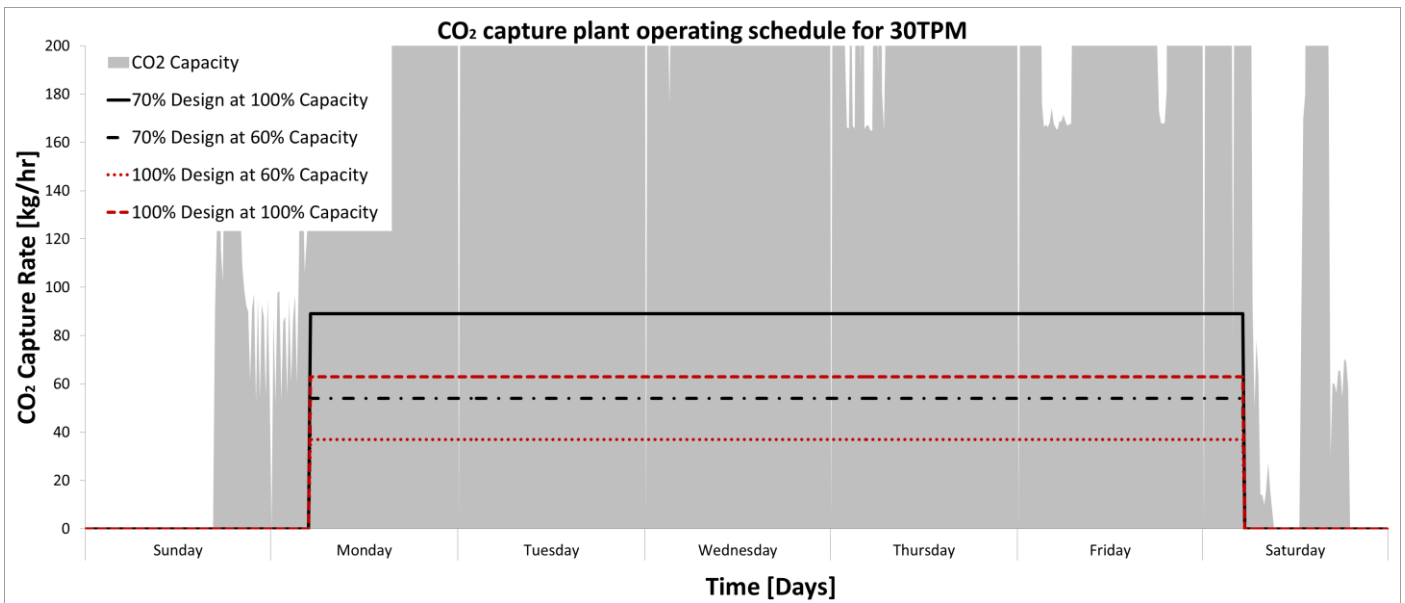

Figure 3: CO₂ capture plant for 30 TPM capacity over 20 days of operation.

6.2.2 Control Theory

The control theory of the amine plant is an automated feedback loop programmed to operate at optimum conditions. All preliminary control is shown in Figure 4 with a red dotted line. Additional control points and sensors might be required in the front end engineering design to effectively integrate the capture plant with the abattoir’s existing infrastructure on a case-by-case basis.

The amine control theory is designed to regulate the ratio between lean amine and the CO₂ content of raw gas for quality assurance. Ratios outside the design parameters can result in off-specification CO₂ gas, solution foaming and inefficient capture process. Hence, the amine control plays a key role in ensuring the quality and efficiency of the capture plant.

The initial gas composition and flow rate transmitter controls the flow of lean amine solution through the absorber column to capture the maximum available CO₂ gas. To ensure the amine solution is maintained at the desired temperature, the reboiler heat load is a function of the amine flowrate. In addition, several level transmitters trigger liquid pumps to transport the amine solution, preventing flooding in the columns and reboiler. Additional pressure transmitters are recommended for the absorber and stripper columns to monitor signs of foaming through erratic pressure drops.

The compressor train control system can be independent of the amine section if a CO₂ holding tank is employed as shown in Figure 4. A pressure transmitter will trigger the compression process when sufficient CO₂ gas is available. Compression intercooling and post cooling is controlled through variable valves and an independent temperature transmitter maintaining a pre-set point. All other refrigeration is controlled similarly through independent temperature transmitters and variable valves. A solenoid is also used to isolate the heat exchanger to prevent temperature creep and for ease of maintenance.

The boiler for steam generation is generally a pressure controlled system with the burners firing between pre-set pressure points. In the case where a biogas scrubber is used, bio-methane from the holding tank can be used in the boilers to supplement natural gas.

The gas composition transmitter before the ICO₂ storage tank ensures the final product meets specifications of food grade CO₂ before storage. This is crucial for quality assurance as the CO₂ is used for product cooling with direct contact. For cases where steady-state raw gas is not available, a control solution is required to adapt to the changing conditions.



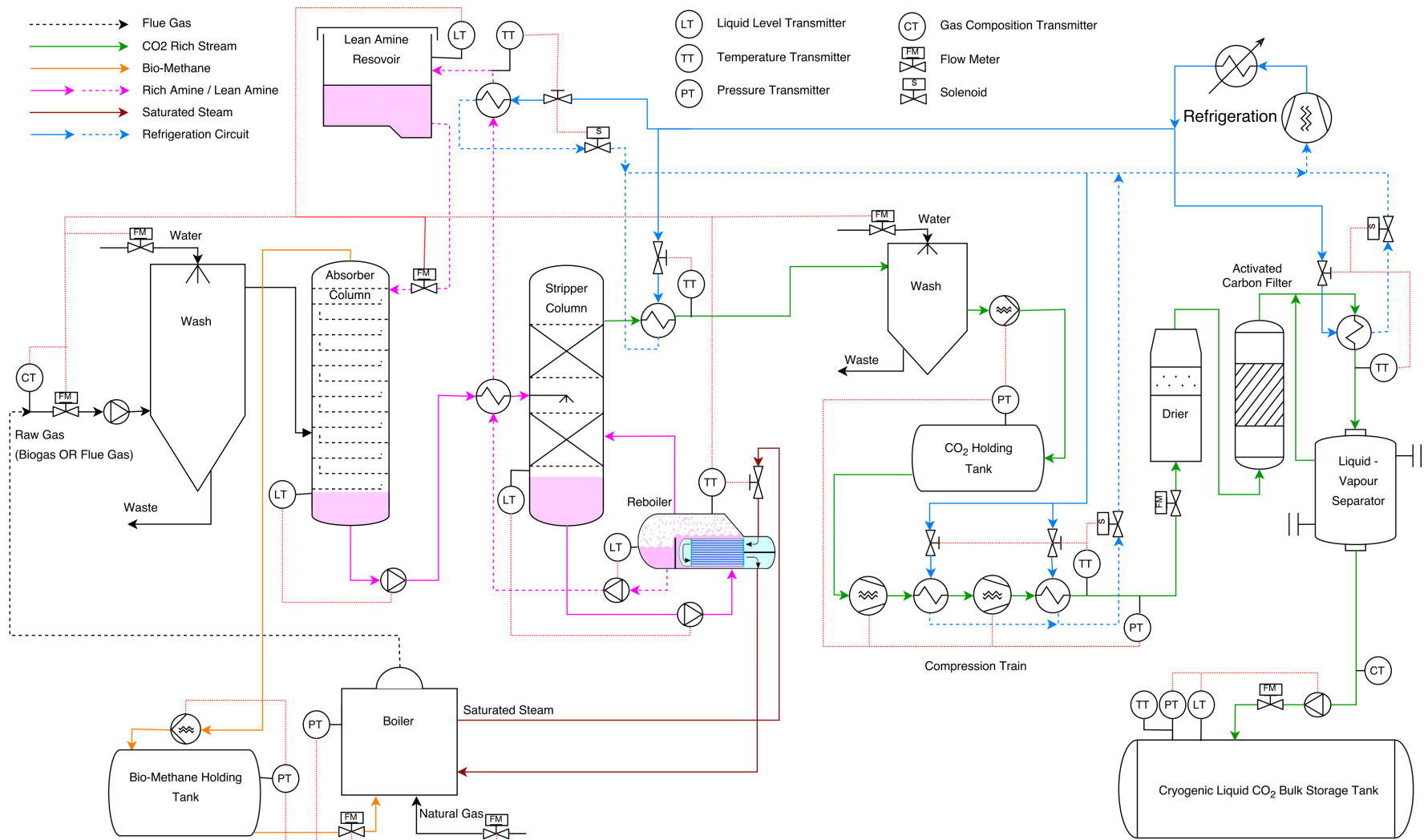

Figure 4: CO₂ capture plant - control theory

6.3 Risk Minimisation Guidelines for Project Execution

Several risk minimisation strategies can be employed to ensure the CO₂ capture project is undertaken successfully. Some of the general risks are discussed below.

- Before interfacing with the existing refrigeration infrastructure, a detailed analysis is required to ensure the cooling load can be maintained at peak operating hours of the abattoir. Furthermore, the installation should take place during the cooler months of the year when the existing refrigeration load is at its minimum.
- The distance between the capture plant and existing refrigeration and CO₂ infrastructure should be kept minimal to reduce possibility of refrigerant leaks and heat gains. Components installed need to be accessible for maintenance and inspections especially to identify and mitigate corrosion. Additionally, ventilation for heat dissipation and chemical leaks must be considered when installing the equipment.
- Depending on the location-specific temperature swing throughout the year, heat tracing might be required for components that are exposed to the amine solution, to prevent solidification of the amine. Amines generally have a solidification temperature of about 0 to 4°C but can vary considerably due to dilution and additives. The lean amine reservoir, in particular, would need to be considered as a heat transfer system to prevent solidification during downtime when the amine is stored in the tank for maintenance.
- The cost of steam also needs to be considered for economic analysis as part of operating costs. The reboiler uses approximately 2.5kg of steam per kg of CO₂ captured. Cost of steam can be estimated between 30 and 35AUD per ton equating to 75 to 88AUD per ton of CO₂ captured. Hence, it is important to appropriately size the reboiler and capture plant to reduce any significant change in operating costs.

6.4 Real Estate and Power Requirements

The real estate and power requirements for a 30TPM plant are outlined in this section. The values provided are approximations and are subject to change on a case-by-case basis with regards to system requirements and components used.

The absorption and stripper columns rely on large height to width ratios to facilitate maximum efficiency of the absorption and stripping processes. The columns are generally around 1m in diameter and about 15-20 m in height. The reboiler has a larger footprint of approximately 4-12m² dependent on the requirement and type of boiler used. The compression train, filtration and liquefaction components are generally skid mounted. These skids can range between 40 and 100m² depending on ventilation and accessibility requirements for maintenance.

The compressor train is the key contributor to power consumption ranging between 70 and 100kW. The refrigeration power load can range between 25 and 50kw, which can be considered as insignificant when integrated with existing infrastructure. Other components such as pumps, actuators and process control components require minimal power demand.

The reboiler heat load is generally supplied through on-site saturated steam at approximately 150°C. The start-up time for the plant is dependent on the reboiler meeting the temperature requirements and therefore steam availability needs to be considered along with the cost of production. If steam is unavailable due to site restrictions, then an electric reboiler can be used increasing operating cost.



7.0 ROADMAP FOR END USERS

Potential end users can use the roadmap as an appraisal process that highlights information required for identifying system sizing and integration options. A flowchart is outlined in Appendix 3 with an overview of the assessment process

- **Capacity of CO₂ in biogas and boiler exhaust** - It is evident from the mass balance analysis in the milestone report, that the biogas scrubber is restricted in production capacity, due to the biogas composition and available volume. The biogas scrubber capacity can be estimated at about 0.35-0.40 kg of CO₂ per kilogram of biogas (with 26% CO₂ content) treated. Whereas, the SGRS capacity can be estimated to be between 1.5 and 2.5 kg of CO₂ per kilogram of fuel combusted.

The capacity in both scenarios would vary significantly with the discrete composition of biogas and the ratio of biogas to natural gas used in the combustion process. Abattoirs that can meet CO₂ demands through biogas scrubbing should ensure the biogas composition meets process specifications. If biogas composition has excessive quantities of NO_x, SO_x, H₂S and VOCs, then additional components will be required in the capture process, increasing CAPEX.

The SGRS system proves to be more versatile due to large CO₂ availability and reduced contaminants after combustion. This allows red meat processors to more readily adopt commercially available capture plants. However, due to the nature of any plant being a 'micro-plant' when compared to existing systems, a FEED study is required to understand the implications of micro-sizing on such a system.

- **Sizing Consideration** - As outlined in Section 6.2.1, a detailed sizing analysis is required, whilst considering the abattoir's operational and CO₂ usage routine, to determine the optimal size

of the capture plant. This will ensure adequate supply of CO₂ is available during peak periods and for future CO₂ demands. Oversizing for potential sale of excess CO₂ to third parties should also be considered for possible reduced ROI.

- **Financial Analysis** – Cost estimation will provide red meat processors a summary of potential CAPEX and OPEX associated with the capture plant, provided the capture method and sizing analysis has been undertaken. Maintenance, operational consumables, utility expenses and plant operating personnel costs need to be considered as part of OPEX. A ROI appraisal can then be established and reviewed for project financial feasibility. A detailed financial feasibility study outlining OPEX, sensitivity to different variables and a ROI assessment is discussed in Project 2016.1038.
- **Showstoppers and High Risk Components** – Showstoppers and high risk components generic to amine absorption plants have been discussed in both the milestone and the current report. These can be adequately mitigated through appropriate design, material selection and effective SOPs. Furthermore, a case-by-case analysis is required to identify other potential on-site risks that might be applicable.

8.0 CONCLUSIONS

The project successfully investigated the detailed design challenges and requirements to integrate a CO₂ capture plant into an existing abattoir infrastructure. A summary of the key findings are as follows:

- Both biogas scrubbing and stack gas recovery can provide a technical solution for capturing CO₂ from an abattoir's existing resources such as biogas or boiler stack gas.

- Amine absorption is a technology that is currently available in Australia providing the best solution for CO₂ capture. The technology has the capacity to be scaled and operated to produce food grade ICO₂ whilst meeting fluctuating demands.
- Biogas scrubbing provides limited quantity for CO₂ capture when compared to SGRS. Hence, the biogas scrubbing might not be a viable option for abattoirs with large CO₂ demands.
- Concept plant design of a capture plant with the required process and instrumentation diagram has been developed with general operating conditions for different components determined.
- Potential showstoppers have been identified and addressed for an operational abattoir to meet requirements.
- High risk components including corrosion, foaming and amine degradation have been addressed. These risks can be mitigated through careful material selection on a case-by-case basis and by adhering to routine inspections and maintenance.
- Optimal sizing of the capture plant is required to meet CO₂ demands while be economically viable. The operating schedule will provide a basis for sizing a capture plant whilst considering the abattoir's weekly operation and CO₂ requirements.
- A control theory of the CO₂ capture plant has been outlined, showing the operating dependency of different components.

9.0 RECOMMENDATIONS

On completion of this report, the following recommendations have been proposed for further investigation:

- A stack gas recovery system is capable of providing a more flexible solution compared to biogas scrubbing, especially for abattoirs with large CO₂ demands. Although biogas scrubbing can provide bio-methane as off-gas, the cost savings when supplementing natural gas are minimal. The stack gas recovery system may also provide the option for red meat processors to sell excess CO₂ captured, reducing the time for ROI.

- A Front End Engineering Design study is recommended to precisely size all components and establish operating parameters and utility expenses. This will enable the development of a detailed financial appraisal and provide better understanding of the technical boundaries of implementing a CO₂ capture plant. The scope of the FEED study should include:
 - Review of the on-site situation
 - Process description and identification of component requirements
 - Gross mass balance for one plant model
 - Detailed process flow diagrams with valve and instrumentation
 - Process skid draft layout
 - Piping isometric sketches and electrical line diagrams
 - Estimation of energy balance
 - Layout plan and elevations for the abattoir
 - Plant safety including operational management, monitoring and OHS
 - Technical data of plant operation for approvals and licensing with relevant government bodies.
 - Ecological relevance including expected emissions as air, noise, liquids and solids
 - Project cost estimation and OPEX within $\pm 10\%$



10.0 BIBLIOGRAPHY

Amine Best Practices, 2007. *Amine Basic Practices Guidelines*.

ASCO, 2015. *CO₂ Production Plants*. [Online]

Available at: <http://www.ascoco2.com/en/products/co2-production-plants/>
[Accessed 10 2015].

BioEnergy, FM, n.d. *Producing and using biogas*. [Online]

Available at: http://adbioresources.org/wp-content/uploads/2013/06/59-80_chapter5_v41.pdf
[Accessed 16 December 2016].

De Rijke, S. J. M., 2012. *CO₂ removal by Amine Absorption and Condensed Rotational Separation: Energy Consumption & Equipment Sizing*, Eindhoven: Technical University Eindhoven.

Demirbas, A., 2010. Natural Gas. In: *Methane Gas Hydrate*. London: Springer London, pp. 57-76.

Eco-Tec, 2016. *Eco-Tec Amine Purification*. [Online]

Available at: <http://eco-tec.com/products/amine-purification/>
[Accessed 29 November 2016].

Elsevier Science Publishers B.V, 1976. *Gas Encyclopaedia*. Elsevier Science Publishers B.V.

European Industrial Gases Association AISBL, 2008. *Carbon Dioxide Source Qualification Quality Standards and Verification*, Brussels: EIGA.

Filchem Australia, 2015. *Activated Carbon*. [Online]

Available at: <http://www.filchem.com.au/products/activated-carbon.php>
[Accessed December 2016].

Fortuna, L., 2016. *Environmental benefits of natural and biogas co-combustion*, Adelaide.

Freund, P. & Kaarstad, O., 2007. *Keeping the lights on*. Oslo, Norway: Universitetsforlaget.

GLP Group, P. L., 2016. *Proposed CO₂ Plant*, Melbourne: GLP Group Ltd.

Idem, R. et al., 2006. Pilot Plant Studies of the CO₂ Capture Performance of Aqueous MEA and Mixed MEA/MDEA Solvents at the University of Regina CO₂ Capture Technology Development Plant and the Boundary Dam CO₂ Capture Demonstration Plant. *Industrial & Chemical Engineering Chemistry*, 45(8), pp. 2414 - 2420.

IEAGHG, 2010. *Corrosion And Materials Selection in CCS Systems*, Cheltenham, United Kingdom: International Energy Agency Greenhouse Gas Research and Development programme.

Linde Engineering, 2016. *CO₂ Purification and Liquefaction*. [Online]

Available at: http://www.linde-engineering.cz/en/process_plants/ccs/co2/co2-purification-and-liquefaction/index.html
[Accessed november 2016].

MacDowell, N. et al., 2010. An overview of CO₂ capture technologies. *Energy and Environmental Science*, Volume 3, pp. 1645-1669.

Mitra, S., 2015. *A Technical Report on Gas Sweetening by Amines*, Mumbai, India: Petrofac Engineering (I) Ltd.

Movagharnejad, K. & Akbari, M., 2011. Simulation of CO₂ Capture Process. *International Journal of Chemical, Molecular, Nuclear, Materials and Metallurgical Engineering*, 5(10).

Nittaya, T., 2014. *Dynamic Modelling and Control of MEA Absorption Processes for CO₂ Capture from Power Plants*, Waterloo, Ontario, Canada: University of Waterloo.

Peterson, A. & Wellinger, A., 2009. Biogas upgrading technologies - developments and innovations. *IEA Bioenergy*.

Roarty, M., 1998. *Natural Gas: Energy for the New Millennium*, Department of the Parliamentary Library.

Ryckebosh, E., Drouillon, M. & Vervaeren, H., 2011. Techniques for transformation of biogas to biomethane. *Journal of biomass and bioenergy*, Volume 35, pp. 1633-1645.

TEGA, n.d. *Saturation table CO₂*. Wuerzburg.

Turco, M., Ausiello, A. & Micoli, L., 2016. *Treatment of Biogas for Feeding High Temperature Fuel Cells*. Switzerland: Springer.

Urban, W. et al., 2009. *Technologies and costs of biogas processing and feeding into the natural gas network*, Oberhausen: Fraunhofer UMSICHT.

Watkins, J. & Tellez, J., n.d. *Overview of Cryogenic Separation*, University of Florida.

Yousef, M. I. A., Eldrainy, A. Y., El-Maghlany, W. M. & Attia, A., 2016. Upgrading biogas by a low-temperature CO₂ removal technique. *Alexandria Engineering Journal*, 55(2), pp. 1143-1150.

Zero, 2011. *Carbon Capture and Storage*, Norway: Zero Enussuib Resiyrce Organisation.



11.0 APPENDICES

Appendix 1 Composition of Carbon Dioxide for Food and Beverages

Table 2: Composition standards of Carbon Dioxide for food and beverage applications (European Industrial Gases Association AISBL, 2008)

Component	Concentration	Units
Carbon Dioxide	99.9	% v/v min.
Moisture	50	ppm v/v max.
Ammonia	2.5	ppm v/v max.
Oxygen	30	ppm v/v max.
Nitrogen Oxides	2.5	ppm v/v max.
Non-Volatile Residue	10	ppm w/w max.
Non-Volatile Organic Residue	5	ppm w/w max.
Phosphine	0.3	ppm v/v max.
Total Volatile Hydrocarbons	50	ppm v/v max.
Acetaldehyde	0.2	ppm v/v max.
Benzene	0.02	ppm v/v max.
Carbon Monoxide	10	ppm v/v max.
Methanol	10	ppm v/v max.
Hydrogen Cyanide	0.5	ppm v/v max.
Total Sulphur	0.1	ppm v/v max.
Taste and Odour in Water	No foreign taste or odour	



Appendix 2 CO₂ Capture Capacity and Natural Gas Consumption

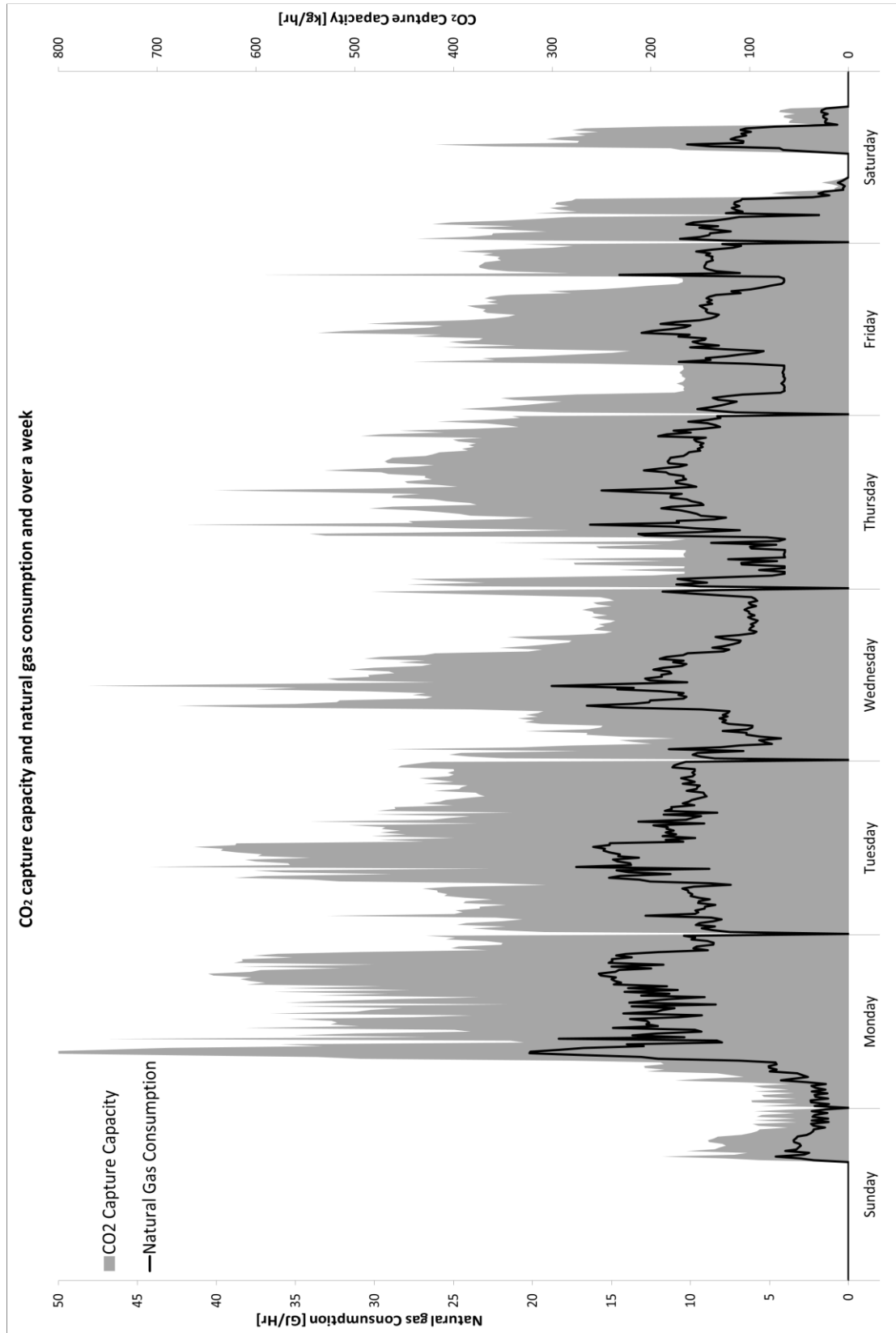

CO₂ capture capacity and natural gas consumption and over a week

Figure 5: CO₂ capture capacity and Natural gas consumption over a week for the corresponding abattoir

Appendix 3 Flowchart for Potential End Users

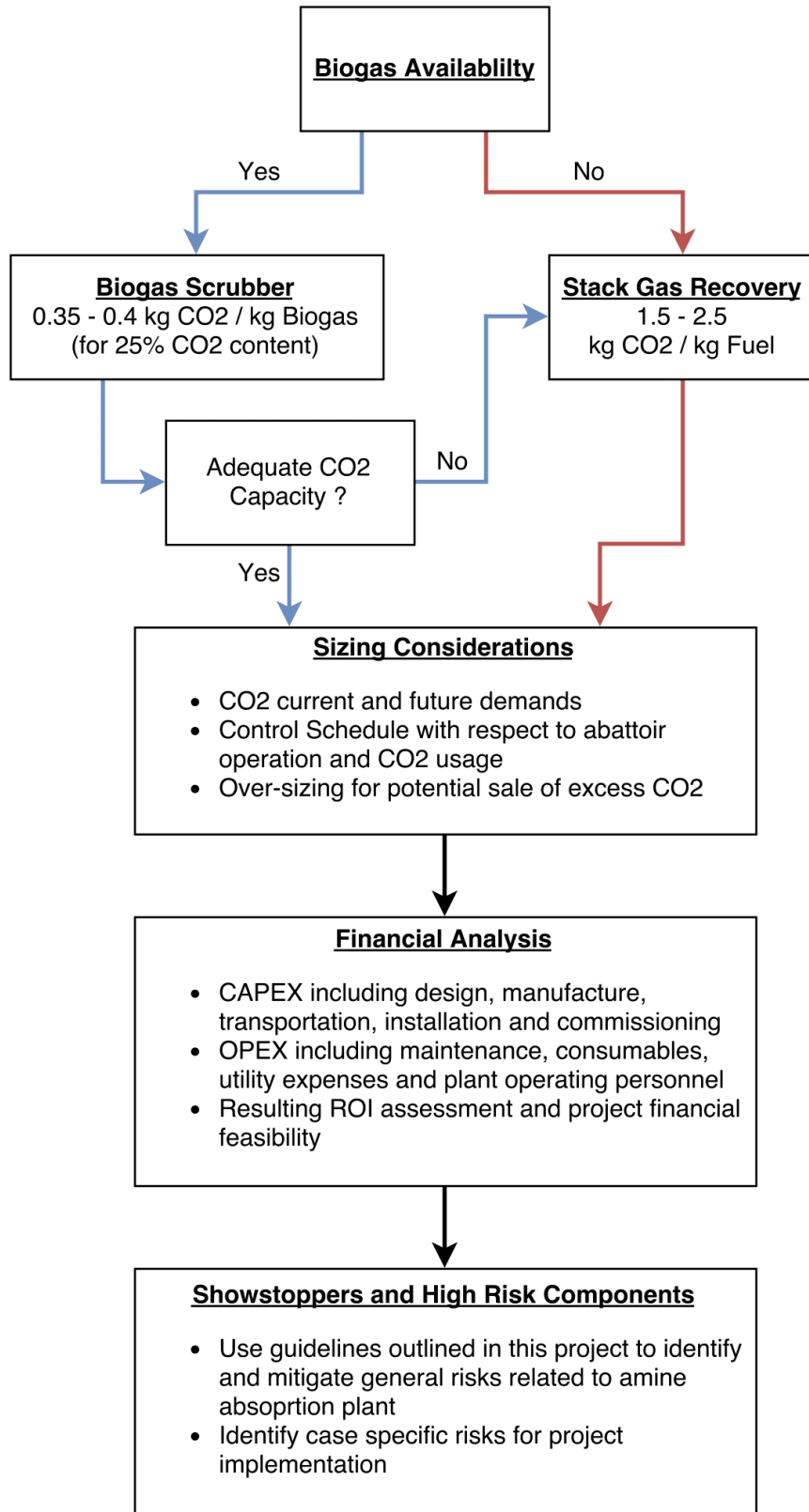

Figure 6: Flowchart for potential end users to determine the feasibility of a CO₂ capture plant at an existing abattoir